

RUBBER EXPANSION JOINTS



ELAFLEX
Group



CONTENT

04	ELAFLEX
06	What are Rubber Expansion Joints
08	Why you should choose ERV
10	Checklist for Expansion Joints
11	Certificates
12	ERV Configurator
13	ERV Product Range
14	Applications
16-31	DITEC Rubber Expansion Joints
32-35	SGB/ELAFLEX Dualsafe
36	Contacts



FLEXIBLE PIPE CONNECTIONS, PREMIUM CLASS.

For pipe construction, you will need compensators to absorb thermal expansion, to reduce vibration and noise. Our 'ERV' rubber expansion joints have reliably performed these tasks since 1956.

Due to their construction and premium quality, our expansion joints have become international industry standard.

This brochure gives an overview of technical features and helps to choose the right product for your needs.

ELAFLEX – EXPERIENCE YOU CAN RELY ON

ELAFLEX is a specialist company in safe connections for refuelling and pipe equipment.

Since 1923 we stand for values which are typical of a family owned company: The spirit of innovation, reliability, continuity and flexibility in thought and action.

ERV expansion joints are an important part of our product portfolio.

The rubber bellows are manufactured in Germany and assembled and distributed by ELAFLEX.

We are a committed partner to our customers who count on quality engineered and durable products. Choosing ERV expansion joints is a sound investment both in terms of performance and total cost of ownership.

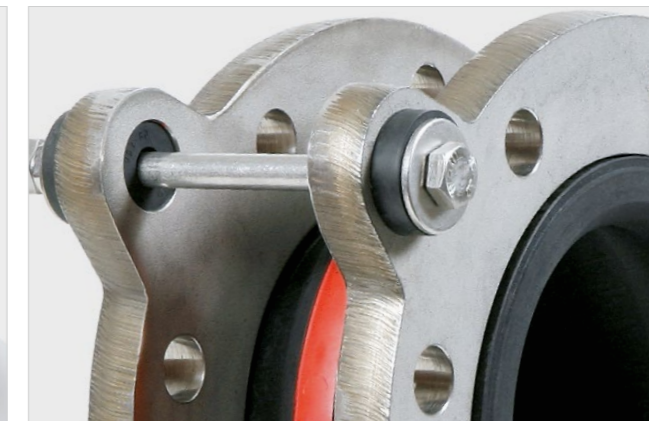

Service and Added Value

ELAFLEX customers appreciate service factors such as professional technical advice, reliability, up-to-date online product information and global support by local ELAFLEX distribution partners.

Service also means the ability to supply a major part of our product range ex works with short lead times. A large 4500 sqm warehouse and a 1350 sqm workshop result in an efficient delivery capability. More than 25.000 bellows and a large number of flanges and accessories are permanently available ex stock.

According to customer specification, we supply the assembled product. Our modular system, developed over the years, is important both for efficiency and for

safe assembling. Bellows, flanges and accessories always come from one source only and to the latest industry standards. The combination of both modular system and control over the whole production chain safeguard that everything fits perfectly.

Our operational procedures also translate into better service. An up-to-date warehouse management system helps for good inventory accuracy and confirmation of readiness for delivery to the customer. Further, a 'pick by voice' and barcode-assisted stock management minimise the possibility of incorrect deliveries and speeds up the delivery process.



WHAT ARE RUBBER EXPANSION JOINTS?

Rubber expansion joints are flexible connectors for the construction of pipe systems.

They relieve system strain by reducing vibration and noise and compensate static or dynamic movements caused by thermal change, load stress, pumping surges or construction settlement.

They also compensate assembling inaccuracies (misalignment during installation) and can be used as pipe insert pieces to facilitate inspections.



Standard length

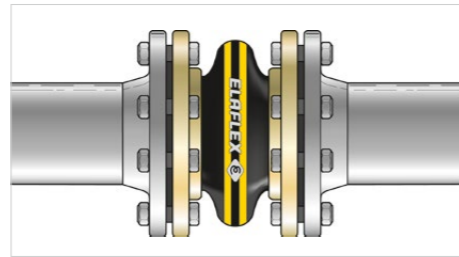

Axial compression

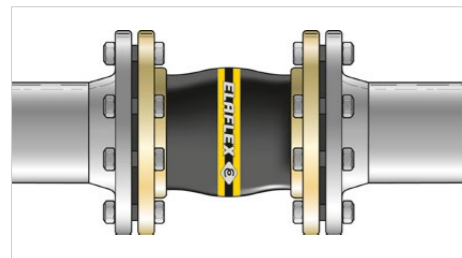

Axial elongation

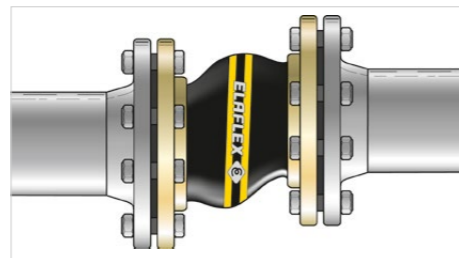

Lateral offset

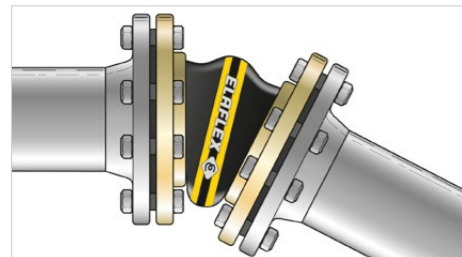

Angular offset



Vibration



Comparing Metal Expansion Joints with Rubber Expansion Joints

Rubber Expansion Joints

- show no fatigue failure due to high frequencies of vibration
- are not endangered by stress corrosion cracking due to their higher flexibility
- are suitable for a larger range of media due to their available type variety
- will absorb outer physical influences, e.g. accidental impacts without any damage
- can be used to protect the pipework against high shock stress
- offer max. movement ranges, at the same time they are very compact (short installation length)
- are suitable to substantially reduce vibration and noise

WHY YOU SHOULD CHOOSE ERV

ERV expansion joints from ELAFLEX are moulded single sphere type rubber bellows with swivelling metal flanges. Their construction and lengths (installation sizes) have since become internationally recognised standard.

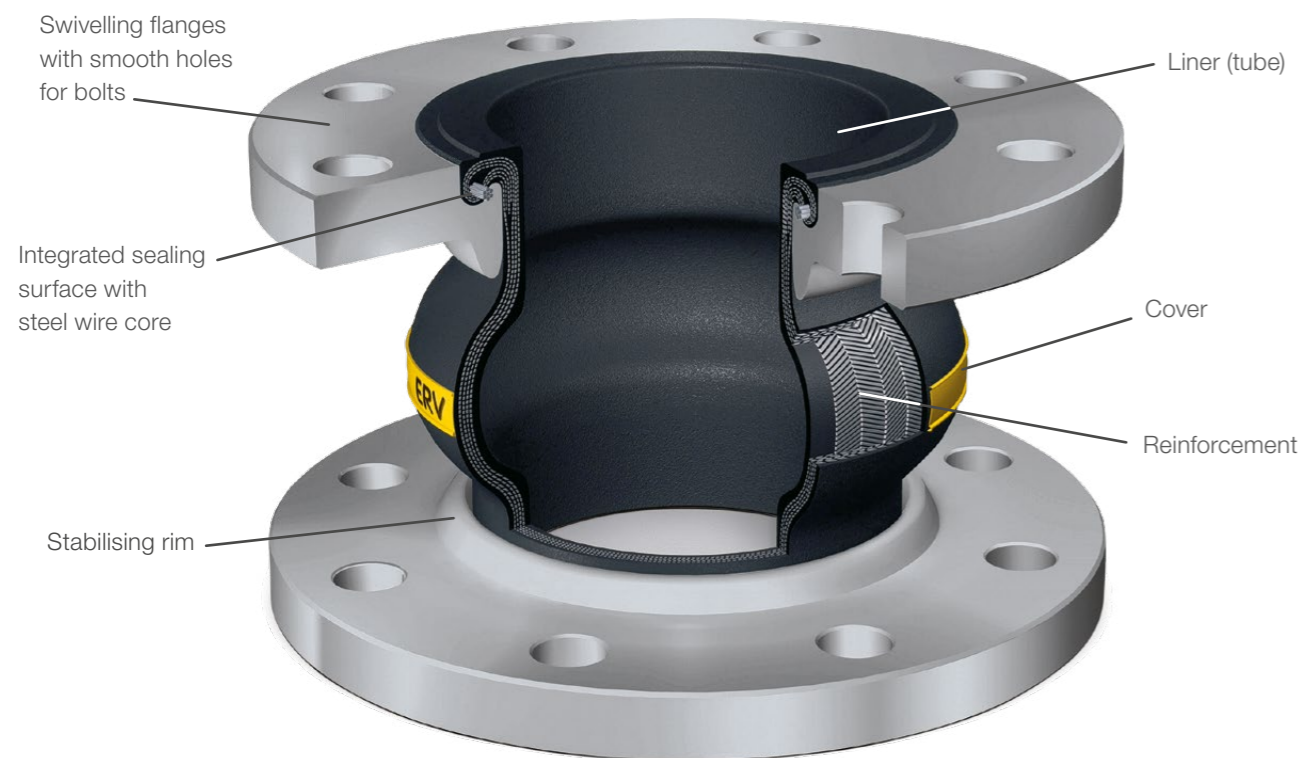

Premium products have their price. But the additional cost for ERV will pay off for the operator in the long run.

The calculation: For a defined period (e.g. 15 years), all direct and indirect costs for a product application with expansion joints are determined and added.

Cost factors include the initial product price, shipping, indirect acquisition expenses, effort for installation and inspection. Most important, the expected lifetime until replacement shall be reflected - including the often non

considered costs arising from product failure: plant downtime, environmental damage and replacement cost.

We claim that – due to their superior lifetime – ERV shows the lowest Total Cost of Ownership, for the major part of applications.

Assuming proper installation and operation within their admissible operating limits, they are trustworthy components for engineers and purchasers who think and calculate in long terms.

Optimal Shape and Construction of the Bellows

- Large axial, lateral and angular range of allowable movement, no double sphere necessary
- Low reaction forces and low inherent resistance
- Noise dampening: the major part of the piping's structure-borne noise and the low-frequency noise generated by fluids is eliminated
- Vibration dampening: ERV efficiently absorb vibrations caused by engines, turbines or compressors

Experience and Know How

- Applications since 1956
- Consistent suppliers and manufacturing methods ensure a constant quality

Customer Focus

- Large warehouse of bellows (>25.000 bellows permanent stock) and flanges/accessories ensure short lead times for standard types
- Technical service: professional advice, documentation, testing certification (audited to European Pressure Equipment Directive)
- Online ERV configurator: ervconfigurator.elaflex.de helps to find and visualize the required product in a few seconds
- Global support by local ELAFLEX distribution partners

Warranty

- Warranty period of 24 months
- Consistent quality results in a neglectable claim rate
- Each examination is free of charge, not depending on the result

Easy Installation

- Swivelling flanges and smooth bolt holes make assembling easy
- The highly flexible bellows eases installation in problematic locations

Certificates

- Various ERV types are certified for civil and navy ship construction, drinking water, foodstuffs, heating and gas supply installations

Superior Life Time

- HiTech rubber compounds
- Physical properties of compounds and reinforcements are optimised for each bellows type: elongation at break, ozone and UV resistance, cold flexibility, tensile strength, volumetric extension, etc.
- Permanent testing of raw material properties – before and during production
- Rubberized reinforcements for superior adhesion of all layers
- Integrated sealing surface with type matched steel wire core
- Made in Germany, ELAFLEX quality philosophy
- High operational safety, 1:4 safety factor regarding burst pressure

Large Product Range

- Variety of 13 different types, sizes 1" – 40" (DN 25 – 1000 mm), various lengths and a vast choice of flange type / material and accessories

The Bellows

- International quality reference for some applications, e.g. ERV-G for tank trucks (fuels), ERV-R for drinking water, ROTEX for heating systems, ERV-OR for LP Gas
- Some unique products such as ERV-GS (ship engine room type approved), ERV-GS HNBR (large application range, temperature, abrasion & fire resistant), ERV-G LT (low temperature down to -40°C)
- Efficient due to standardised bellows lengths

Flanges

- Modular system – flanges match with all bellows
- Certified materials, EN 10204 - 3.1
- Standard types with stabilising rim
- Marked with size, standard, material, manufacturer
- Cr (VI)-free corrosion protection for steel flanges long-lasting and environmentally friendly

CHECKLIST FOR EXPANSION JOINTS

If you are not sure about the required type, execution and flange material, going through this checklist helps us to quote according to your needs.

1. Medium

- Chemical composition
- Gaseous, liquid, paste-like
- Abrasion by solid particles expected

3. Operating Site

- Indoor or outdoor
- Exposure to sunlight (UV)
- Salt-containing atmosphere

2. Operation Conditions

- Minimum/maximum temperature
- Maximum pressure/peaks/load changes
- Vacuum possible
- Axial range of movement (elongation/compression)
- Angular Load
- Lateral offset

4. Certificates and Testing

- Required certificates and/or testing, e.g. to European Pressure Equipment Directive

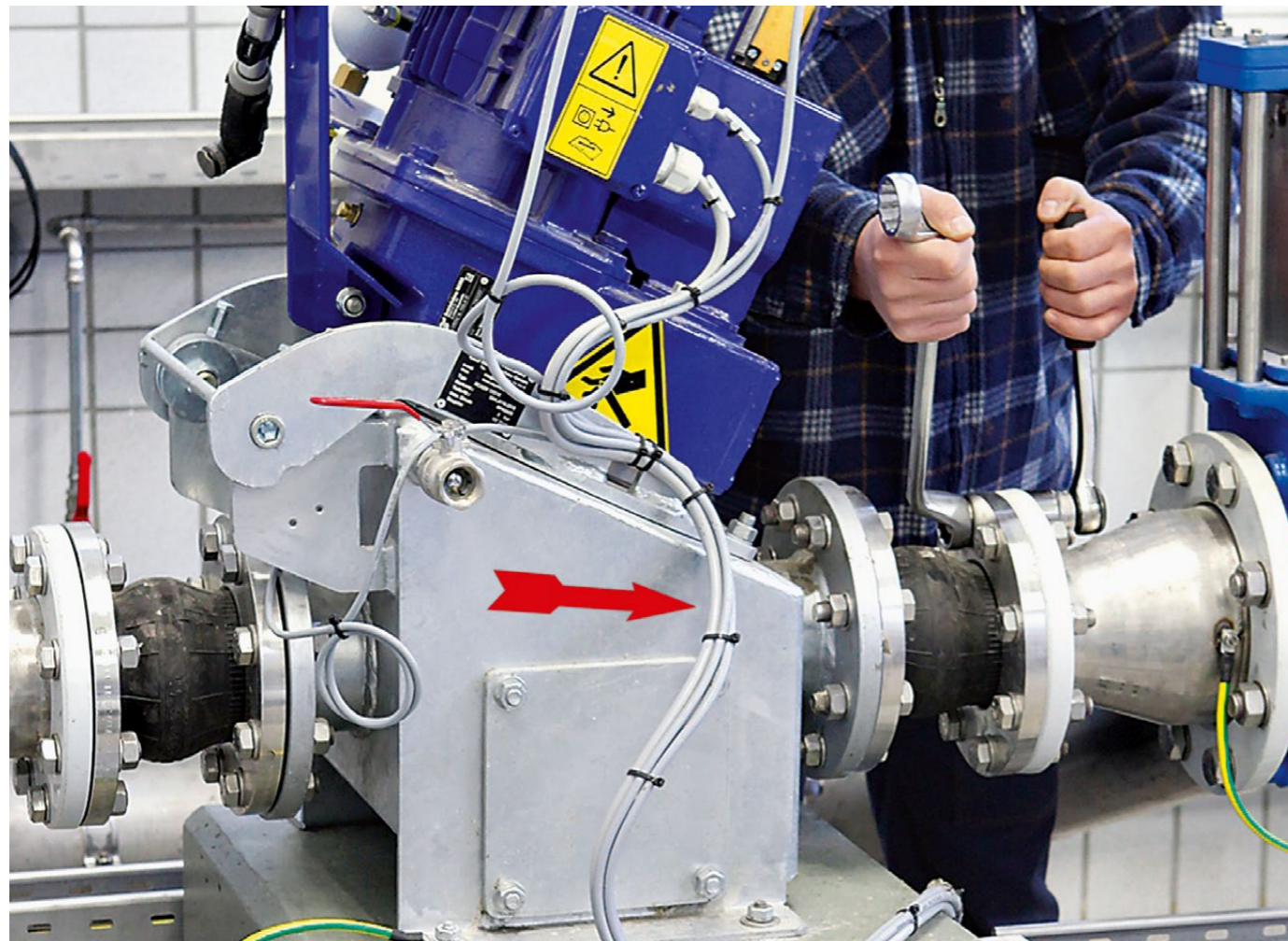

CERTIFICATES

Approvals	ERV-GS	ERV-GS HNBR	ERV-G	ERV-R	ROTEX	ERV-CR	Other
DNV (Det Norske Veritas)	✓	✓	✓	✓	✓	✓	✓ all
Lloyd's Register	✓	✓	✓	✓	✓		
Bureau Veritas	✓	✓	✓	✓		✓	
RINA Services S.p.A.	✓	✓	✓	✓	✓	✓	✓ (ERV-BR, -OR, -GR)
American Bureau of Shipping	✓	✓	✓	✓			
Nippon Kaiji Kyokai	✓	✓	✓	✓	✓		
China Classification Society	✓	✓	✓	✓		✓	
Korean Register	✓	✓	✓	✓			
Dienststelle Schiffssicherheit BG Verkehr *)		✓	✓				Marine Equipment Directive
Technischer Überwachungs-Verein						✓ DIN 4809	
BAAINBW			✓	✓			
Attestation de Conformité Sanitaire				✓			Drinking water
Water Regulations Advisory Scheme				✓			✓ (ERP)

*) Certificate expires in a year, after which it will probably be replaced by DNV.

PDF of certificates can be downloaded under www.elaflex.de/en/certificates/erv

ERV CONFIGURATOR

Many options, fast choice: The online ERV configurator ervconfigurator.elaflex.de helps to combine bellows, flanges and accessories.

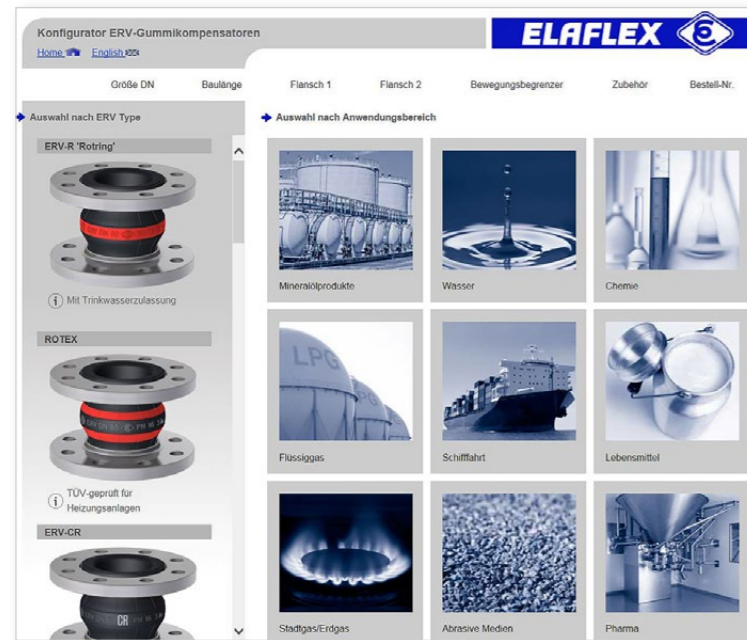

Choose

- Bellows type
- Size (DN) and length
- Flange standard and material
- Movement limiters
- Accessories

A direct enquiry is possible and you can also save the link or PDF on your computer if required.



ERV PRODUCT RANGE

ERV high quality expansion joints DN 25-1000 by ELAFLEX. With swiveling flanges (various types and materials). For detailed information see ELAFLEX catalogue.

<h3>ERV - R</h3> <p>RED BAND expansion joint for water, drinking water, waste water, seawater, cooling water, chemical waste water (without oil), chemicals, acids and alkalis, salt solutions, alcohols. Temperature range -40°C up to +100°C, temporarily up to +120°C. Lining Butyl/EPDM.</p>  <p>Type ERV - R</p>	<h3>ROTEX</h3> <p>ROTEX expansion joint for permanent service with heating water, cooling water and hot air (without oil). W.P. 10 bar up to +100°C, 6 bar up to +110°C. Temperature range -40°C up to +130°C, temporarily up to +150°C. TÜV approved for heating installations. Lining EPDM.</p>  <p>Type ROTEX</p>	<h3>ERV - CR</h3> <p>CR expansion joint for cold and warm water, seawater (also oil containing), various waste water, lube oils and greases, air, compressed air. Temperature range -25°C up to +90°C, temporarily up to +100°C. Lining Chloroprene.</p>  <p>Type ERV - CR</p>	
<h3>ERV - BR</h3> <p>BR expansion joint for abrasive media such as sludges, solid/liquid mixtures, dustlike and powdery products. Temperature range -50°C up to +70°C, temporarily up to +90°C. Lining BR/NR.</p>  <p>Type ERV - BR</p>	<h3>ERP</h3> <p>RED SPOT expansion joint for sanitary facilities, cold/warm water, swimming pool water, seawater, drinking water. Highly flexible + low own resistance. W.P. max. 10 bar. Temperature range -40°C up to +90°C, temporarily up to +120°C. Lining Butyl / EPDM.</p>  <p>Type ERP</p>	<h3>ERV - G</h3> <p>YELLOW BAND expansion joint for petroleum based products up to 50% aromatics, also town gas and natural gas, cooling water emulsions with corrosion preventing oil. Temperature range -20°C up to +90°C, temporarily up to +100°C. Lining NBR.</p>  <p>Type ERV - G</p>	
<h3>ERV - GS</h3> <p>YELLOW STEEL expansion joint. Similar to type ERV-G, but fire resistant to ISO 15540 (type approved). Temperature range -20°C up to +90°C, temporarily up to +100°C. Lining NBR.</p>  <p>Type ERV - GS</p>	<h3>ERV - GS HBNR</h3> <p>YELLOW STEEL HBNR expansion joint for petroleum based products up to 50% aromatics and hydraulic oil. Very good ageing, weathering and ozone resistance. Temperature range -35°C up to +100°C, temporarily up to +120°C. Lining HNBR.</p>  <p>Type ERV - GS HBNR</p>	<h3>ERV - G LT</h3> <p>YELLOW BAND LT expansion joint designed for low temperature applications for petroleum based products. Temperature range -40°C up to +90°C, temporarily up to +100°C. Lining NBR.</p>  <p>Type ERV - G LT</p>	
<h3>ERV - OR</h3> <p>ORANGE BAND expansion joint for Liquid Petroleum Gas (LPG) according to EN 589. Temperature range -20°C up to +90°C. Working pressure 25 bar, burst pressure > 100 bar. Lining NBR.</p>  <p>Type ERV - OR</p>	<h3>ERV - GR</h3> <p>GREEN BAND expansion joint for acids, alkalis, chemicals and aggressive chemical waste water. Temperature range -20°C up to +100°C, temporarily up to +110°C. For oil contaminated compressor air up to +90°C. Lining CSM.</p>  <p>Type ERV - GR</p>	<h3>ERV - W</h3> <p>WHITE BAND expansion joint for foodstuffs, also oils and fat containing food. Lining conforms to German foodstuff regulations. Temperature range -20°C up to +90°C, temporarily up to +100°C. Lining NBR, light grey.</p>  <p>Type ERV - W</p>	
<h3>ERV - G AF</h3> <p>ERV-G AF rubber expansion joints for all aviation fuels to aviation hose standard EN ISO 1825 / EI 1529. Temperature range -40°C up to +65°C. Working pressure 20 bar. Lining Special Compound.</p>  <p>Type ERV - G AF</p>			<h3>Accessories</h3> <ul style="list-style-type: none"> • Tie rods with outer limitation (...ZS) • Tie rods with inner and outer limitation (...ZSS) • Angular limiter (...RG) • Inner protection sleeve stainless steel (...SR) • PTFE liner (...TA) • PTFE liner and vacuum support ring (...TAS) • Vacuum support spiral stainless steel (...VSD) • Vacuum support ring stainless steel (...VSR) • Bolted vacuum support ring stainless (...VSRV) • Flame protection cover (...FSH) • Flame protection cover Naval Standard (...FSH-M) • Earth Cover (...EAH)

APPLICATIONS

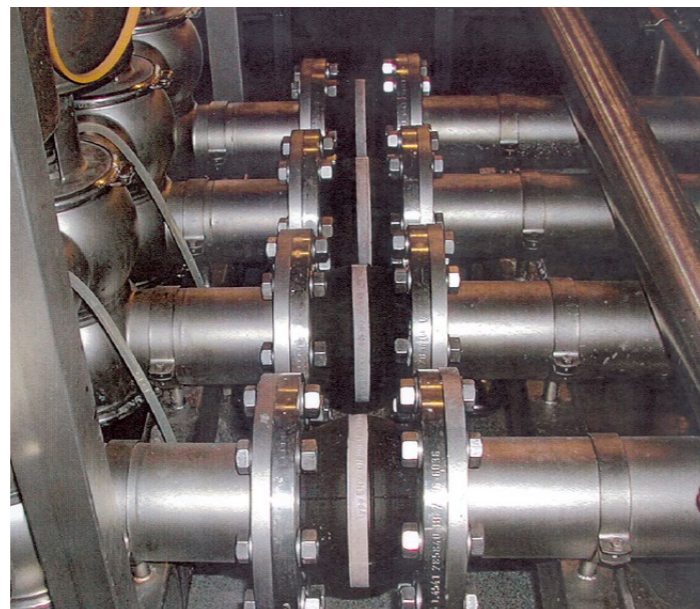
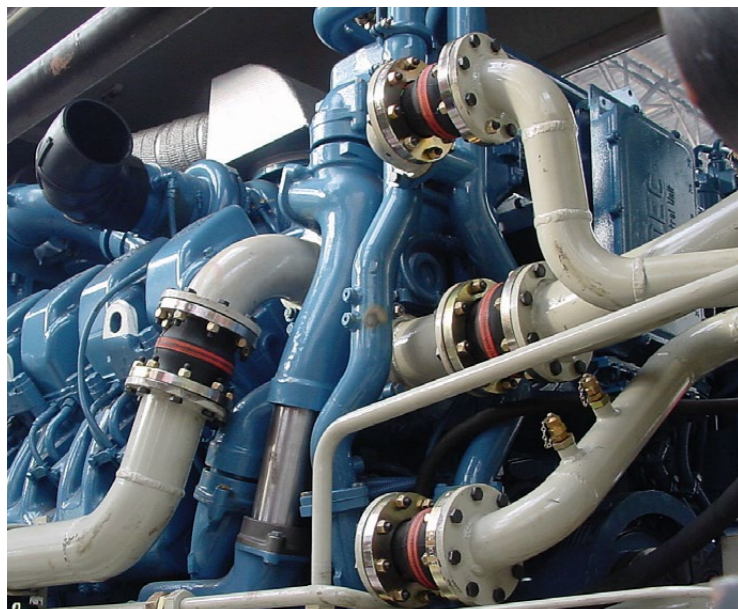
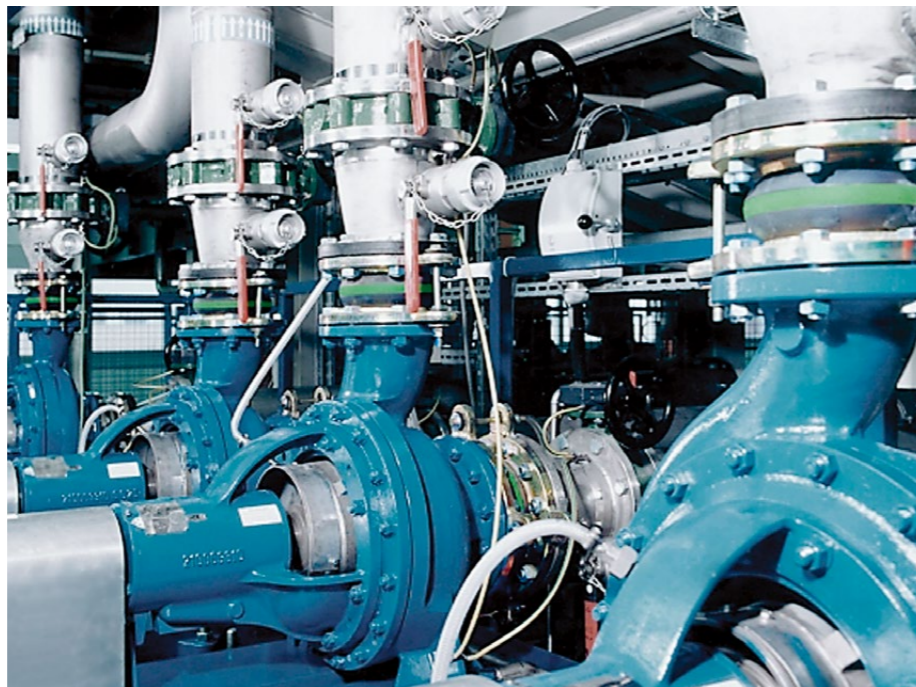
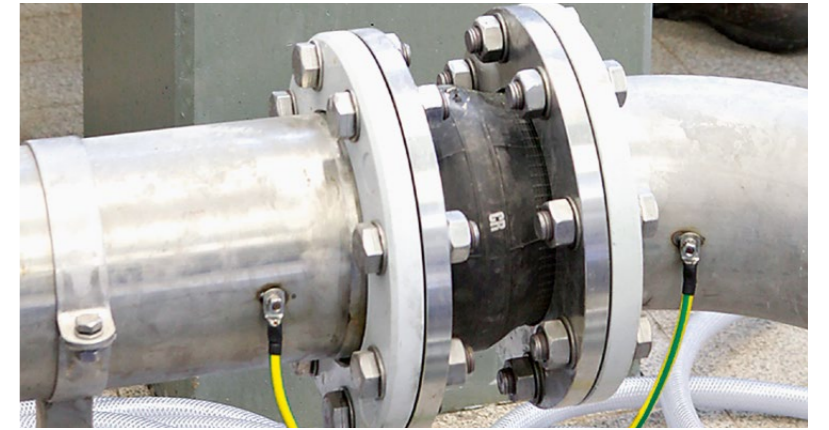



MEMBER OF THE
ELAFLEX GROUP

Highest Flexibility

- › Piping Rubber Expansion Joints
- › Penetration Seals
- › Dog Bone Expansion Joints
- › Fabric Expansion Joints
- › Rubber Moulded Parts

YOUR PARTNER – DITEC DICHTUNGS- TECHNIK GMBH

Through specialisation, our company has positioned itself as a worldwide leading manufacturer of rubber and fabric expansion joints. As a developer and manufacturer, we focus on our customers' demands. We make the seemingly impossible possible – with a high degree of technical expertise and commitment, combined with decades of experience. We rise to every challenge.



ditec-adam.de

We are partners,
manufacturers and problem solvers.





DITEC PRODUCTS

For round, rectangular, oval or other designs, we are one of the few manufacturers worldwide who can produce large rubber expansion joints for high pressures up to DN 5000 and larger.



ditec-adam.de/brochure

PIPING RUBBER EXPANSION JOINTS

Gummikompensatoren



PENETRATION SEALS

Abdichtungen für Wanddurchführungen



DOG BONE EXPANSION JOINTS

Dog Bone Kompensatoren

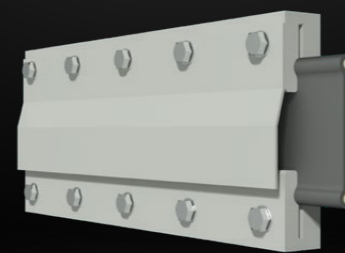

FABRIC EXPANSION JOINTS

Gewebekompensatoren



RUBBER MOULDED PARTS

Gummiformteile



CUSTOMIZED SOLUTIONS

It goes without saying that we are at your side as a contact partner for individual requirements. This also applies in seemingly impossible cases – whether complex designs, extreme operating conditions or extraordinary dimensions.

Even during the design and quotation phase, we use Finite Element Methods and 3D models to check the functionality of the expansion joint. You can integrate these into your piping models to detect collisions with adjacent components at an early stage.

Contact us – we will be happy to advise you on a customer- and application-specific solution.



ditec-adam.de/en/contact



MARKETS & APPLICATIONS

Founded in 1973, since then ditec Dichtungstechnik GmbH has been a manufacturer of expansion joints for a wide variety of markets, industries and requirements.

- > Power Plant Technology
- > Industry and Plant Engineering
- > Water Treatment Technology
- > Basic and Chemical Industry
- > Paper and Pulp Industry
- > Food Industry
- > Ship Building Industry



DITEC KNOW-HOW

Each of the products we deliver is backed by many years of know-how and in-depth expertise in the design and manufacture of expansion joints. We adapt individually to your requirements. In addition to the dimensions, you tell us all the operating conditions, such as flow medium, pressure, temperature and movements, and you will receive a product precisely tailored to these requirements.

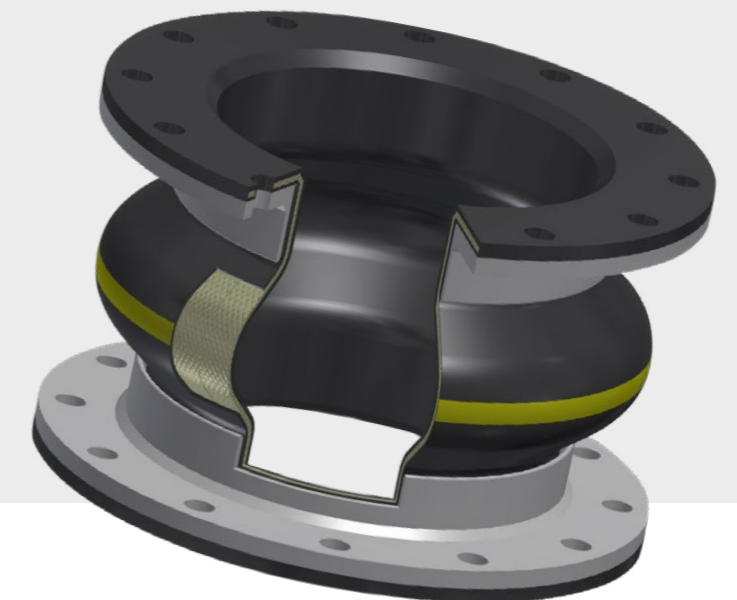
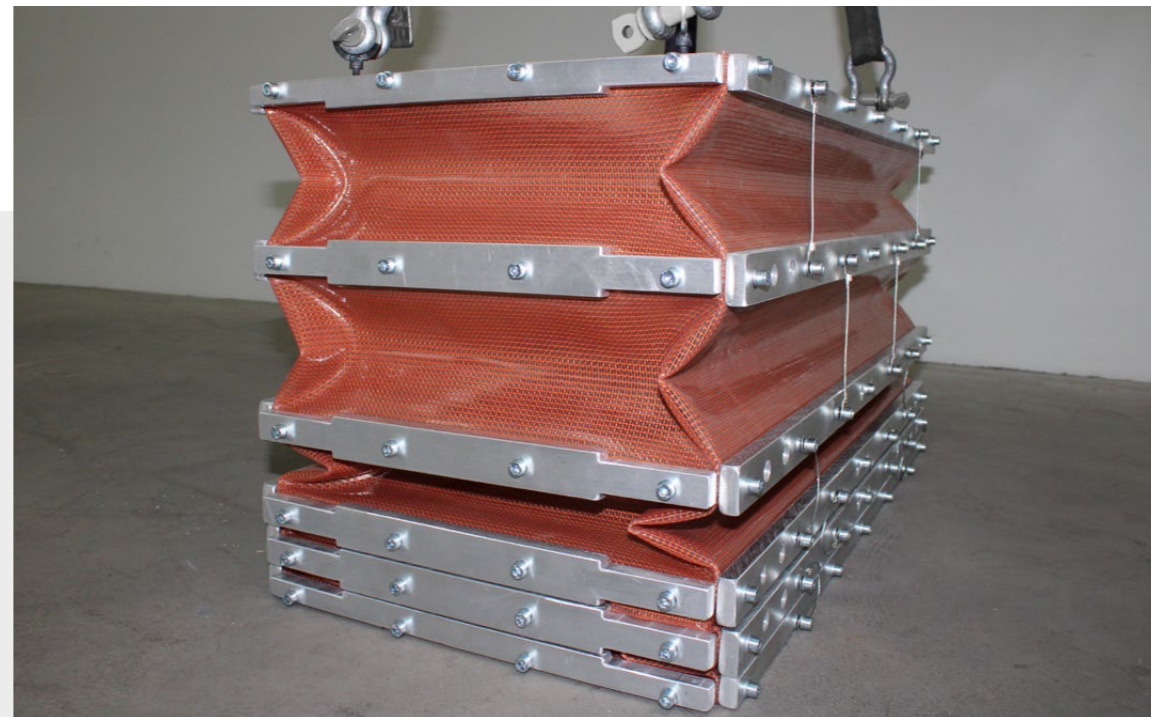

100% MADE IN GERMANY

Yesterday, as today, we produce 100% of our expansion joints where they are also developed: at our headquarter in Kitzingen.

On an area of 17,600 square meters, we have production facilities specializing in the manufacture of rubber and fabric expansion joints and the entire workflow from the initial idea to the delivery of the products. All this including own mold making, own calendering plant and own vulcanization autoclaves. A directly affiliated metal construction company for the production of expansion joint accessories such as flanges, support rings and baffles offers our customers and us additional flexibility.

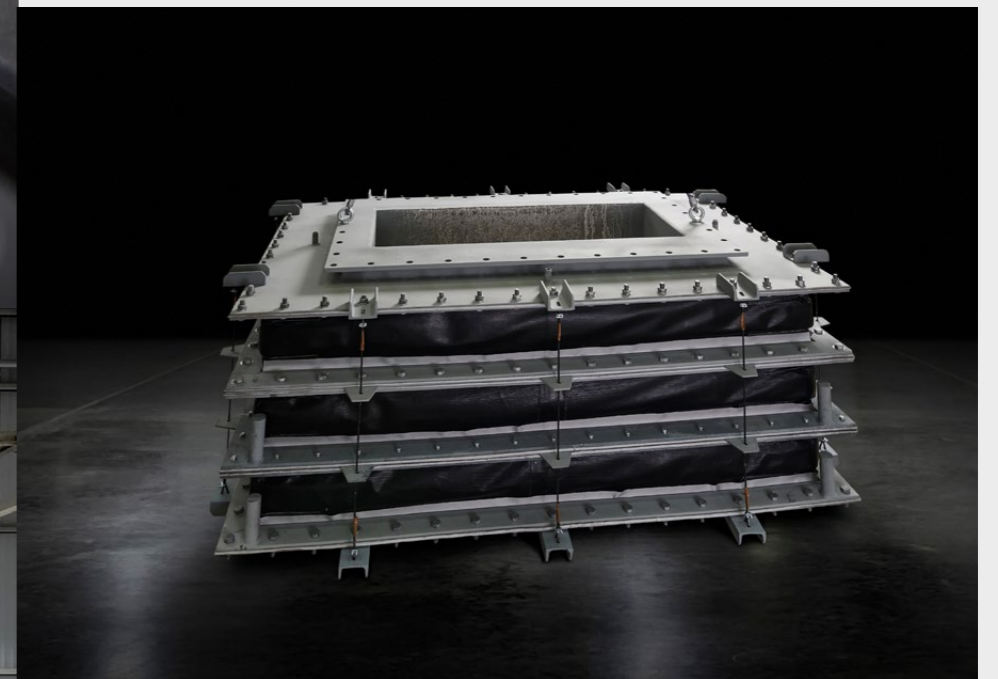



QUALITY PROMISE

The secret of our success lies in our almost 50 years of experience and expertise. This is made up of our production facilities, a functioning integrated Management System and comprehensive Testing. This is how we achieve the highest standards, which are confirmed by our certifications. ditec Expansion Joints undergo a series of controls and tests at each of the different steps in the manufacturing process and before they leave the factory.

- › Hydrostatic pressure testing
- › Vacuum testing
- › Burst pressure testing
- › Cycle life testing
- › Spring rate testing
- › Movement capabilities testing
- › Elastomer chemical analysis
- › Fluid and chemical compatibility test
- › Electrical properties



ELAFLEX DUALSAFE

DOUBLEWALL RUBBER
EXPANSION JOINTS



ELAFLEX 

SGB

SAFETY, DOUBLED!

Transfer of environmental hazardous and water-polluting media confronts everyone involved with numerous challenges and strict regulations, for example Directive EU 2020/2184 or GGVSEB. No fluid is allowed to escape into the environment. Full protection of people, environment and ground water as source for drinking water – regardless of the medium or weather conditions – must be guaranteed under all conditions and at all times. Preparations and provision/installation of equipment such as spill containment require extensive personnel, material and time resources for each individual transfer or refuelling operation.

To fulfil the regulations for protection of drinking water at random places, the new ELAFLEX DualSafe in combination with our tightness monitoring system helps reduce effort and cost. It is suitable for a broad spectrum of applications such as ship bunkering or liquid logistics in sensitive environment without specific preparation. In combination with the ELAFLEX products dry disconnect and breakaway couplings a safe transfer system will be formed.

The ELAFLEX DualSafe solution is available for ELAFLEX Yellow Band hoses like HD, TW or LTW and all chemical hoses acc. to EN 12115. The available size ranges from DN 15 to DN 80. Thanks to the proven leak detection system from ELAFLEX Group's industry expert SGB, DualSafe can be used anywhere and significantly simplifies resource planning processes. It works as a flexible replacement for liquid-tight loading zones with retention basins and also meets the requirements of nature conservation areas. The SGB leak detection system provides a visual, acoustic and electrical signal whenever the vacuum in the monitored space is compromised.

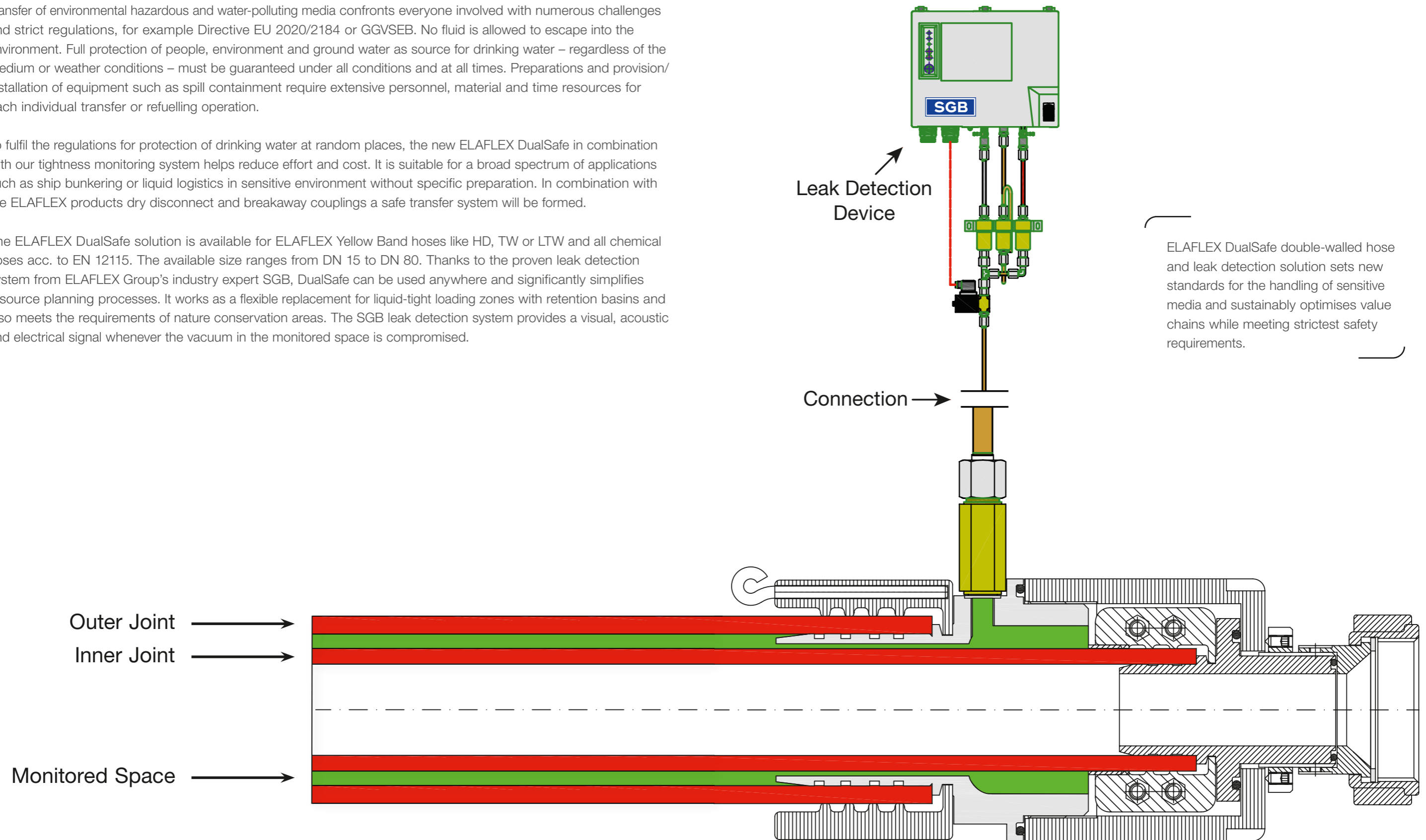

ELAFLEX DualSafe double-walled hose and leak detection solution sets new standards for the handling of sensitive media and sustainably optimises value chains while meeting strictest safety requirements.

THE ELAFLEX GROUP

// Air Traffic Trade

Aljac

DANTEC

ditec

Oasis

ELAFLEX

MannTek

SGB

REIFLEXA



Contact data of our approximately
150 distribution partners worldwide:

elaflex.com/contact/distribution-partners

ELAFLEX WORLDWIDE

Air Traffic Trade AB Sweden	Måttbandsvägen 12 18766 Täby Tel. +46 8-768 39 90 info@airtt.se airtt.se	ELAFLEX FRANCE SARL France	Aktipark 50 Rue des Chardonnerets, Lot N° 3 93290 Tremblay en France Tel. +33 1 41 84 06 22 info@elaflex.fr elaflex.fr	ELAFLEX Yakıt İletim Ürünleri Ltd. Şti. Turkey	42 Maslak Plaza Ahi Evran Street No:6 34485 Maslak - Sarıyer İstanbul, Turkey Tel. +90 212 974 1020 batuhan.kiroglu@elaflex.com elaflex.com.tr
Aljac GmbH Germany	c/o ELAFLEX HIBY GmbH & Co. KG Schnackenburgallee 121 22525 Hamburg Tel. +49 40 6908 4116 info@aljac.de aljac.de	ELAFLEX ITALIA SRL Italy	Via Industriale 28 25086 Rezzato (BS) Tel. +39 030 249 61 00 info@elaflex.it elaflex.it	Mann Teknik AB Sweden	Strandvägen 16 54231 Mariestad Tel. +46 501 39 32 00 sales@manntek.se manntek.se
Aljac Fuelling Components Ltd. Great Britain	Unit 1a, Watchmore Point Camberly, Surrey GU15 3AD Tel. +44 1932 269869 sales@aljac.com aljac.com	ELAFLEX Latin America S.A. Argentina	Talcahuano 945, Martínez (1640) Buenos Aires, Argentina Tel. +54 11 4836-3510 ventas.latinamerica@elaflex.com.ar elaflex.com.ar	Mann Teknik China China	Building C, No 505, 23rd Street, Qian Tang District, Hangzhou Tel. +86 571-87695112 info@manntek.cn manntek.cn
DANTEC LTD Great Britain	Tarran Way, Moreton, Wirral CH46 4TL Tel. +44 151 678 2222 sales@dantec.com dantec.com	ELAFLEX LTD Great Britain	Riverside House Plumpton Road Hoddesdon, Herts EN11 0PA Tel. +44 1992 45 29 50 sales@elaflex.co.uk elaflex.co.uk	MannTek Couplings India Pvt. Ltd. India	Office No. LF7A/7B Lotus Aura, Sama -Savli Road, Vadodara - 390008, Gujarat Tel. +91 9558 825 855
ditec Dichtungstechnik GmbH Germany	An der Staustufe 6 97318 Kitzingen Tel. +49 9321 2307-0 info@ditec-adam.de ditec-adam.de	ELAFLEX NV Belgium	Merksemsesteenweg 192 2100 Deurne (Antwerp) Tel. +32 3 32 80 420 info@elaflex.be elaflex.be	Oasis Engineering Limited New Zealand	129 Birch Avenue Tauranga, 3110 Tel. +64 7 928 3808 info@oasisngv.com oasisngv.com
ELAFLEX AB Sweden	Måttbandsvägen 12 18766 Täby Tel. +46 8 980 130 info@elaflex.se elaflex.se	ELAFLEX PACIFIC PTY LTD Australia	Unit 29/58 Box Road Taren Point NSW 2229 Tel. +61 2 9525 0945 info@elaflex.com.au elaflex.com.au	SGB GmbH Germany	Hofstraße 10 57076 Siegen Tel. +49 271 48964-0 sgb@sgb.de sgb.de
ELAFLEX HIBY Asia-Pacific Pte. Ltd. Singapore	Mr. Marvin Lambert Office Singapore Tel. +65 8486 4435 marvin.lambert@elaflex.com	ELAFLEX Representation Office China	Mr. Jing Fan Room 1120, 1101 South Pudong Road, 200120 Shanghai, P.R. China Tel. +86 21 505 414 54 fan.jing@elaflex.net.cn elaflex.com	ELAFLEX Group	
ELAFLEX BRAZIL Eireli Brazil	Avenida Brigadeiro Luis Antonio, N° 300 8° andar sala 82 Bela vista, São Paulo-SP Brazil - CEP 01318-903 Tel. +55 11 4153-2171 vendas.brasil@elaflex.com.ar elaflex.com.ar	ELAFLEX US Inc. USA	11310 Slater Ave Fountain Valley, CA 92708 Tel. +1 888 472 7444 info@elaflexus.com elaflexus.com	ELAFLEXHIBY GmbH & Co. KG Schnackenburgallee 121 22525 Hamburg Germany Tel. +49 40 540005-0 info@elaflex-group.com elaflex-group.com	