

ELAFLEX Hose Reels are supplied as a complete customised package incl. our hoses, couplings and nozzles.

Hose Reels '**Compact Line B**' with automatic spring-loaded rewind system, used for retraction of Elaflex hoses up to 20 m in max. DN 25.

The small and lightweight design makes it easy to handle. To ensure a larger capacity and a proper distribution of the hose spirals on the drum, the OUT connection is placed outside the disks, hose is guided through disk.

Suitable for a wide range of media, e.g. gasoline, diesel, aviation fuels, urea solution (AdBlue®), detergents, solvents, oils, water, gases and others. For example: Slimline 'SL' 21 with ZVA Slimline 2 for boat refuelling.

MATERIALS

Frame: available in polyester powder coated carbon steel, UV resistant (on request: cataphoresis treatment or zinc plated) or stainless steel (AISI 304 or AISI 316L).

Wet parts: available in carbon steel or stainless steel (AISI 304 or AISI 316L).

Swivel joint: available in zinc plated carbon steel, brass or stainless steel (AISI 303/AISI 316L), in 90° or straight shape*).

Working pressure up to 200 bar*).

*) depending on materials

COLOURS



RAL 5017



RAL 3002



Special Colours

(on request)

MOUNTING POSITIONS

The integrated mounting plate is removable and suits for plain (Pos. A) or vertical (Pos. B) surfaces.

The mounting plate can be easily fixed on the corresponding holes of sidewall plates.

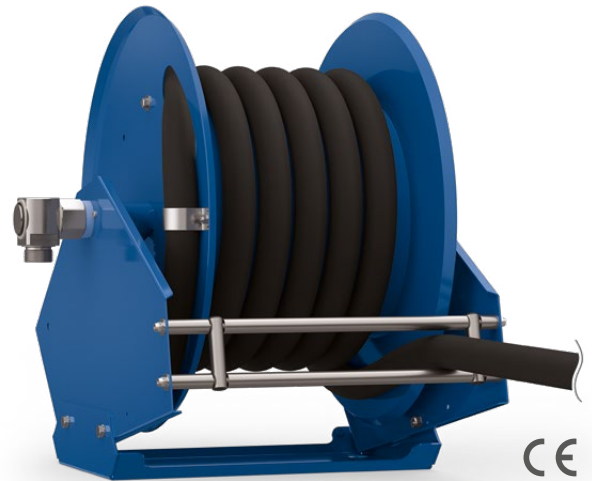

Cert. ATEX Dir 94/9/CE
Gr. II Cat. 2 GD c IIB TX
Zone 1, 2, 21, 22

Mounting Position A: Plain Surface

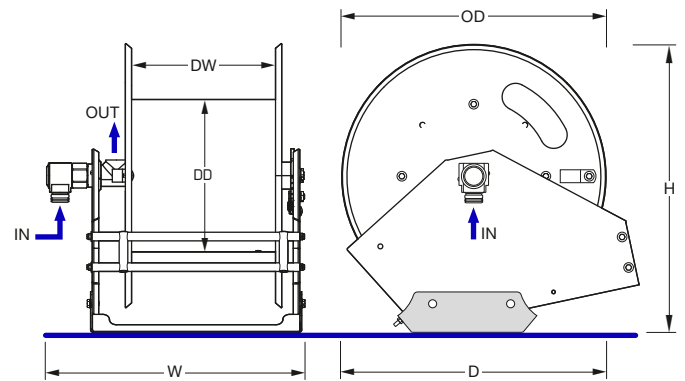

Mounting Position B: Vertical Surface

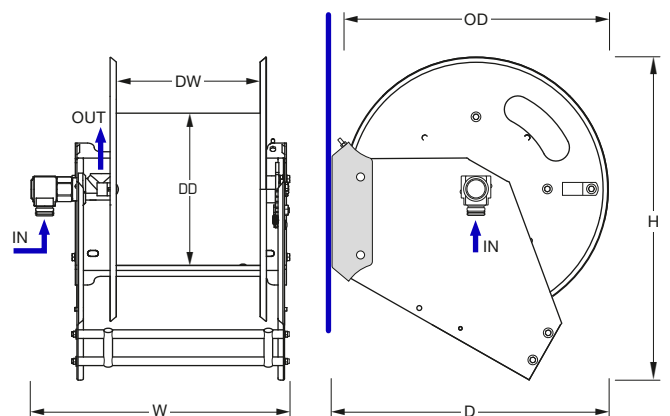

Recommended Hose		Connections	Drum Diameter	Disc Diameter	Dimensions Position A	Dimensions Position B	Weight	Standard Part Number
max. Length	max. DN	IN / OUT	DD Ø (mm)	OD Ø (mm)	W x D x H (mm)	W x D x H (mm)	kg	Type
20 m	DN 25	1" bsp male / 1" bsp female	283	490	480 x 550 x 535	480 x 515 x 600	26	HR CL B

Please contact our sales team to check capacity when smaller hose diameters are required.

FEATURES

ANTI-KINKING SLEEVE (1)

The Anti-Kinking Sleeve is useful to avoid kinking of the hose around the disc during the assembly.

DRUM STOP MECHANISM (2)

All our spring rewind hose reels are equipped with a durable Drum Stop of stainless steel or steel FE 510 OR to avoid the accidental hose rewinding. It is also not burdening the operator by permanently pulling the hose against spring force.

HOSE GUIDE (3)

The static Hose Guide is integrated in the frame with durable PVC or stainless steel rollers. The bearings are maintenance free self-lubricating. The Hose Guide for 'Compact Line B' is provided in low position as standard.

ACCESSORIES

SWIVEL BRACKET FOR WALL INSTALLATION (4)

The Swivel Bracket enables the hose reel to follow the hose direction. It ensures an easy handling and tidy hose rewinding.

SWIVEL SUPPORT FOR PLAIN INSTALLATION (5)

The Swivel Support is suitable for turning the hose reel in the required direction.

It is used for a plain surface (Pos. A) and allows a free rotation of the reel on its central pin enabling rotations up to 360°.

The integrated lock can fix the reel in the chosen position in 20° steps.

HOSE STOPS (6)

The hose reels can be supplied with a Hose Stop. It prevents the complete rewinding of the hose and can be placed anywhere along the hose assembly to the chosen of the hose length. Shape and dimension can vary according to the hose diameter.

